

ASSEMBLY INSTRUCTION

MODEL : TBB30

PART	QTY
A ALLEN KEY	1 Pc

PART	QTY
C M6 x 35mm	8 Pcs

PART	QTY
E CSK M3.5 x 16mm D x 6	2 Sets

PART	QTY
G BARREL NUT	8 Pcs

PART	QTY
B JCBC M6 x 16mm	8 Pcs

PART	QTY
D M3.5 x 20mm	16 Pcs

PART	QTY
F YBV20	2 Sets

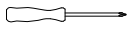
<i>Tools Required</i>	
 SCREWDRIVER	

STEP 1

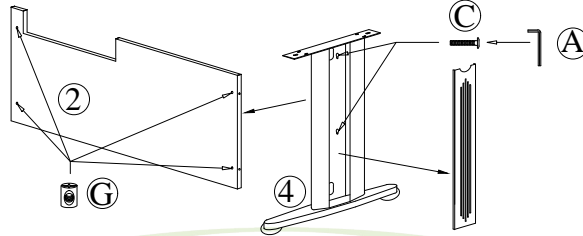

STEP 2

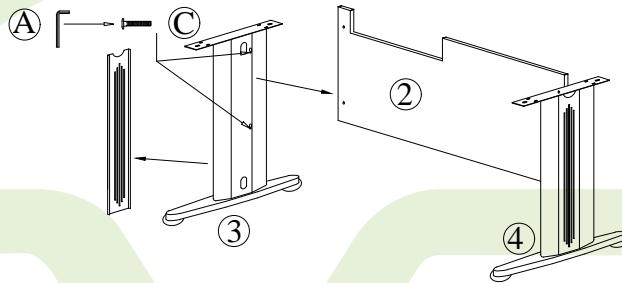

STEP 3

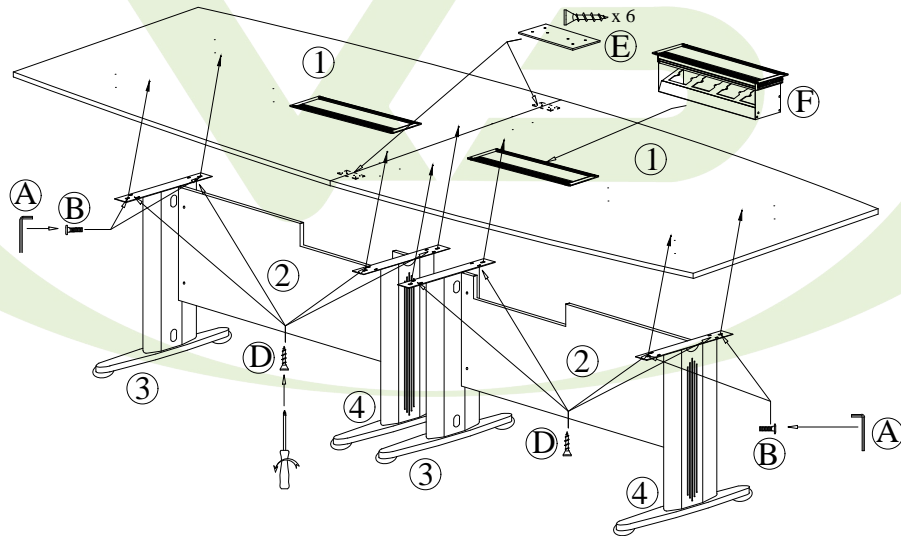

FINISHING

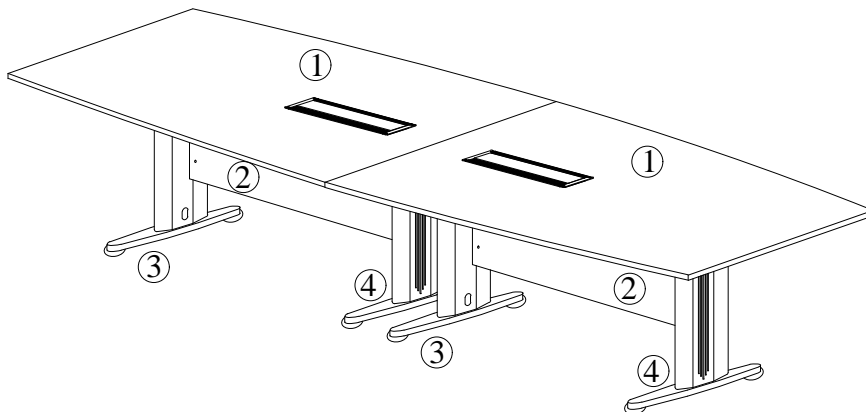

ASSEMBLY INSTRUCTION

MODEL : TVE24

PART	QTY
A ALLEN KEY	1 Pc

PART	QTY
C M6 x 35mm	4 Pcs

PART	QTY
E BARREL NUT	4 Pcs

PART	QTY
B JCBC M6 x 16mm	4 Pcs

PART	QTY
D M3.5 x 20mm	8 Pcs

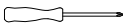
<i>Tools Required</i>	
	
SCREWDRIVER	

STEP 1

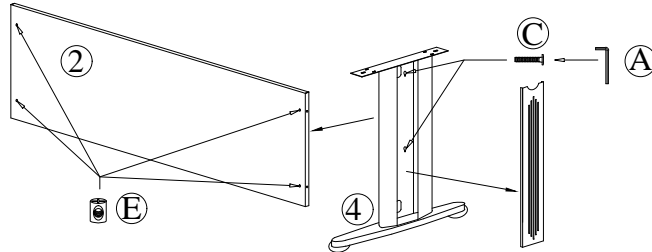

STEP 2

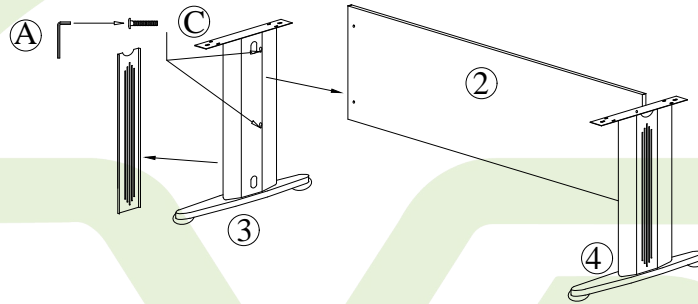

STEP 3

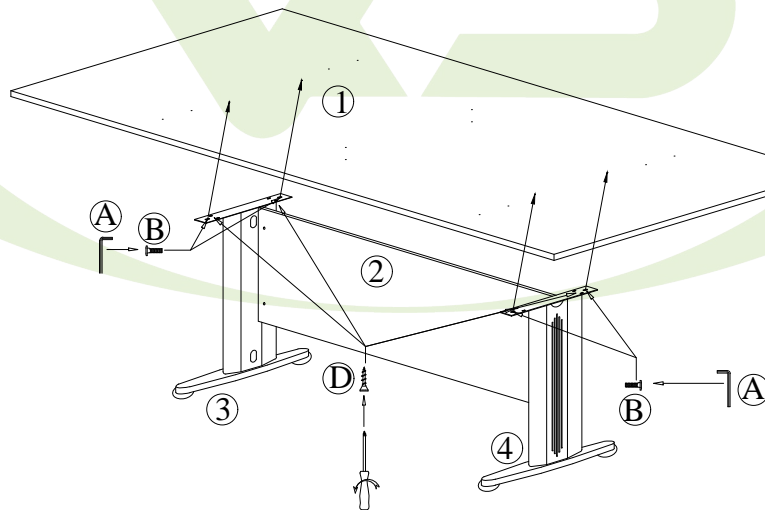

FINISHING

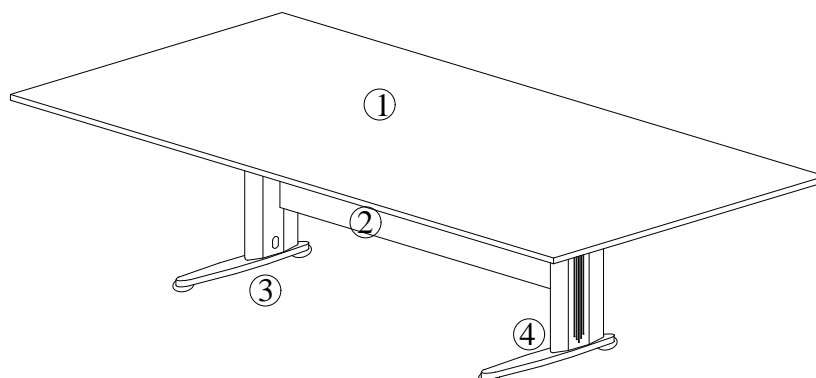

ASSEMBLY INSTRUCTION

MODEL : TVE18

PART	QTY
A ALLEN KEY	1 Pc

PART	QTY
C M6 x 35mm	4 Pcs

PART	QTY
E BARREL NUT	4 Pcs

PART	QTY
B JCBC M6 x 16mm	4 Pcs

PART	QTY
D M3.5 x 20mm	8 Pcs

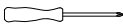
<i>Tools Required</i>	
	
SCREWDRIVER	

STEP 1

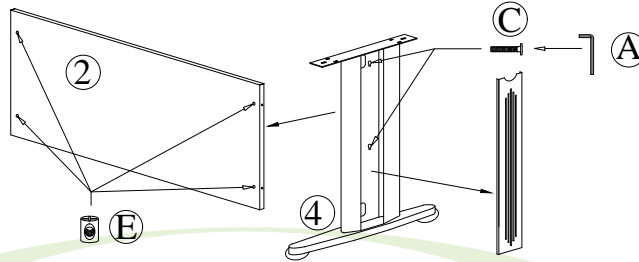

STEP 2

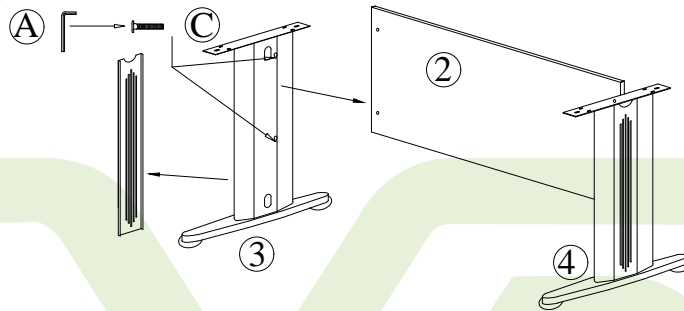

STEP 3

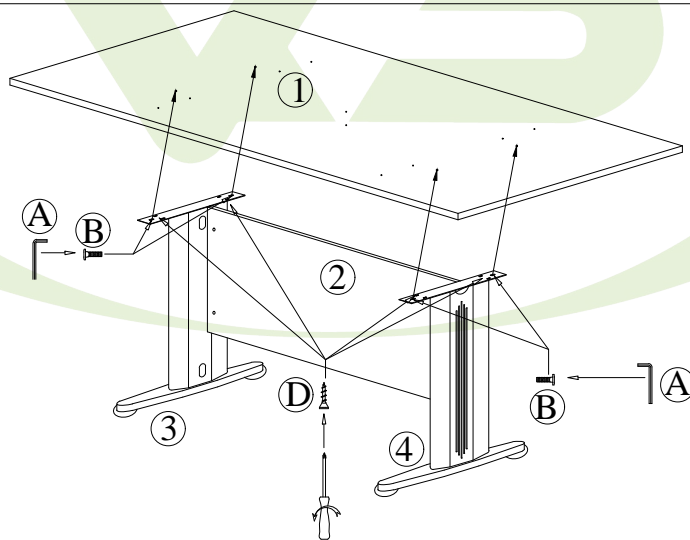

FINISHING

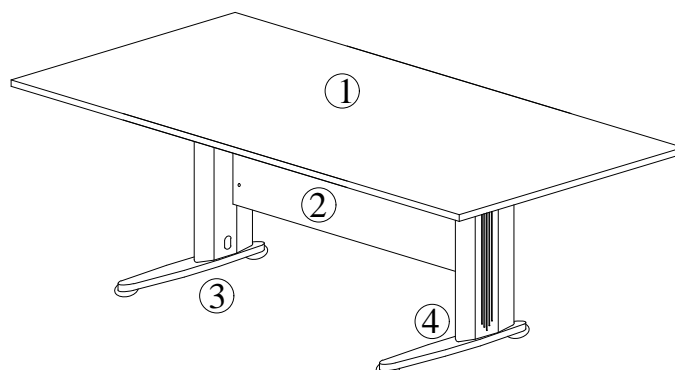

ASSEMBLY INSTRUCTION

MODEL : TT188

PART	QTY
A ALLEN KEY	1 Pc

PART	QTY
C M6 x 35mm	4 Pcs

PART	QTY
E BARREL NUT	4 Pcs

PART	QTY
B JCBC M6 x 16mm	4 Pcs

PART	QTY
D M3.5 x 20mm	8 Pcs

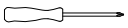
<i>Tools Required</i>	
	
SCREWDRIVER	

STEP 1

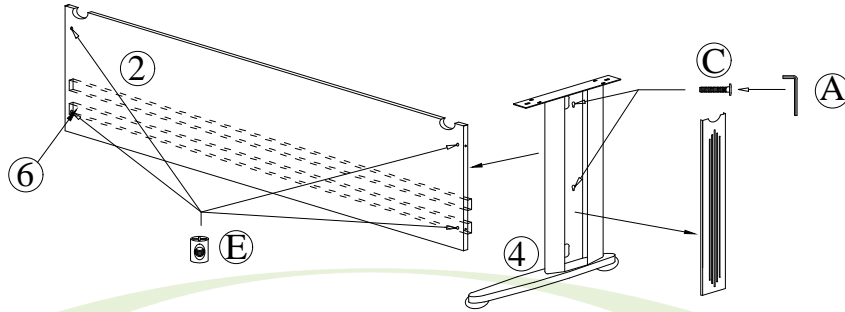

STEP 2 (A)

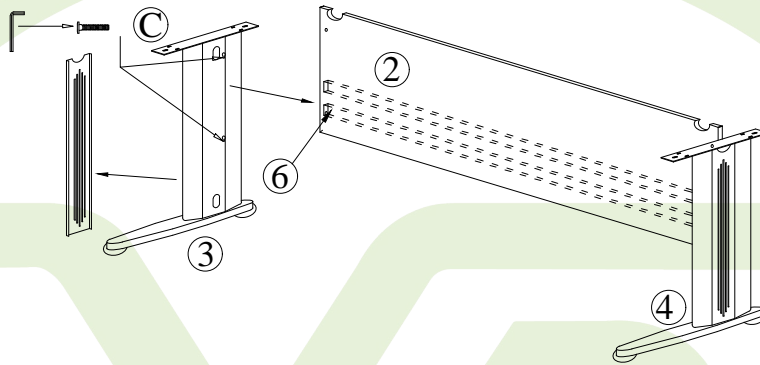

STEP 3

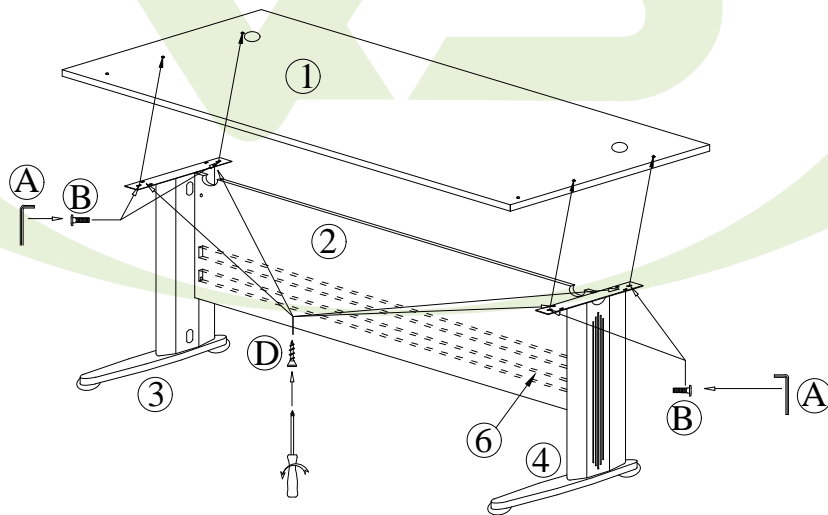

FINISHING

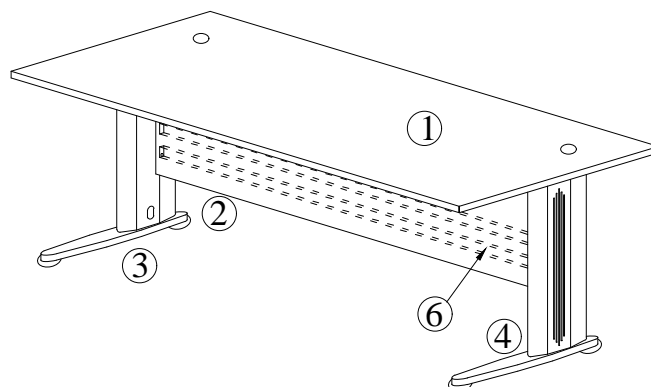

ASSEMBLY INSTRUCTION

MODEL : TT158

PART	QTY
A ALLEN KEY	1 Pc

PART	QTY
C M6 x 35mm	4 Pcs

PART	QTY
E BARREL NUT	4 Pcs

PART	QTY
B JCBC M6 x 16mm	4 Pcs

PART	QTY
D M3.5 x 20mm	8 Pcs

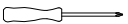
<i>Tools Required</i>	
	
SCREWDRIVER	

STEP 1

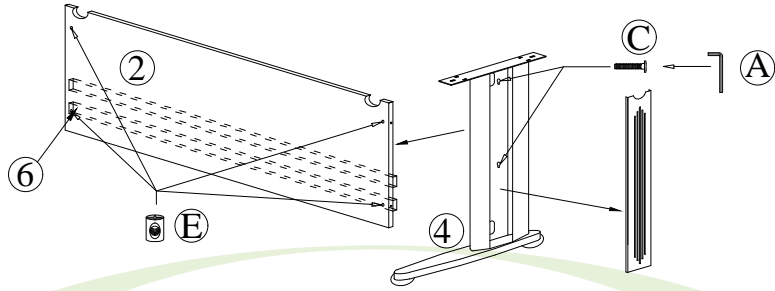

STEP 2

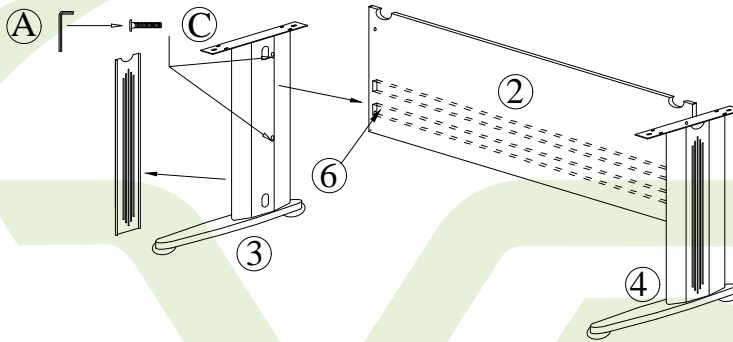

STEP 3

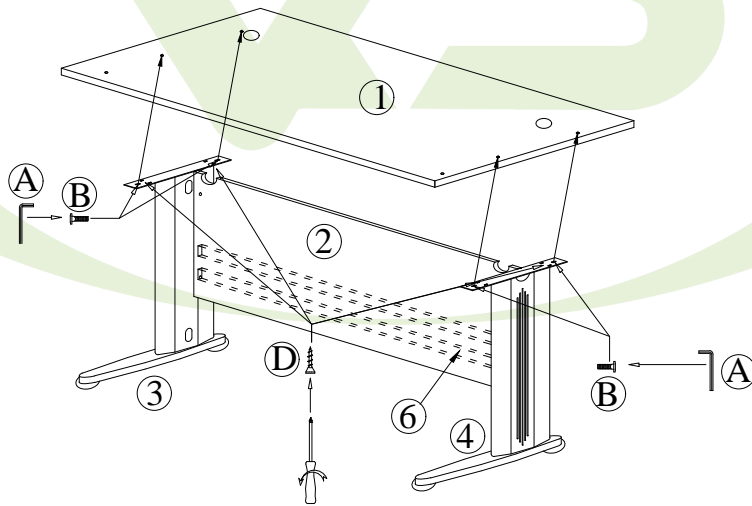

FINISHING

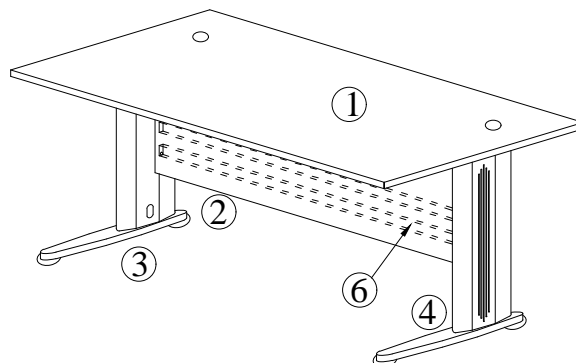

ASSEMBLY INSTRUCTION

MODEL : TT156

PART	QTY
A ALLEN KEY	1 Pc

PART	QTY
C M6 x 35mm	4 Pcs

PART	QTY
E BARREL NUT	4 Pcs

PART	QTY
B JCBC M6 x 16mm	4 Pcs

PART	QTY
D M3.5 x 20mm	8 Pcs

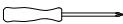
<i>Tools Required</i>	
	
SCREWDRIVER	

STEP 1

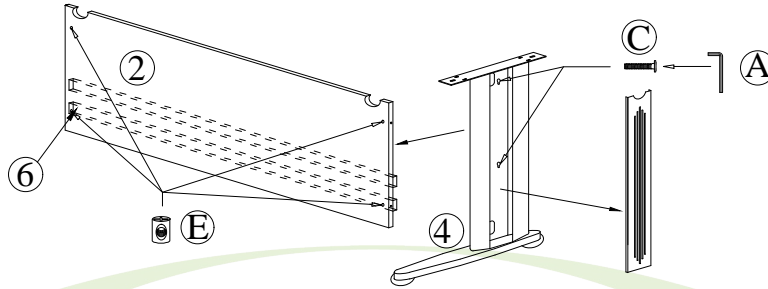

STEP 2

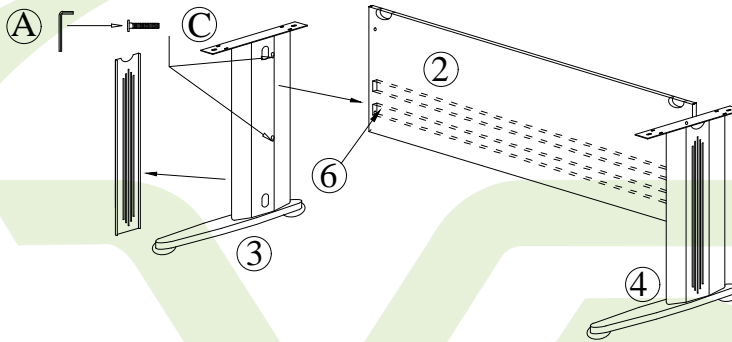

STEP 3

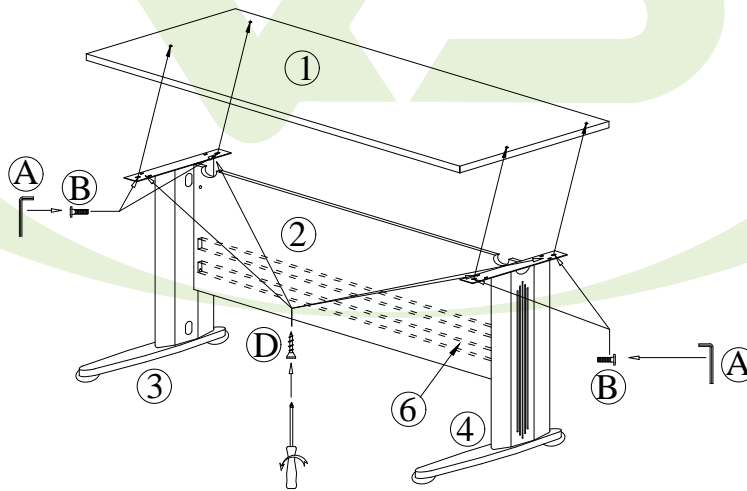

FINISHING

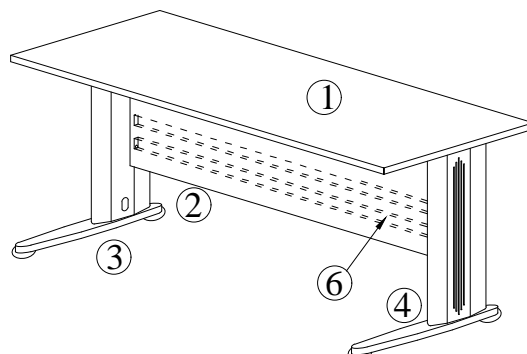

ASSEMBLY INSTRUCTION

MODEL : TT128

PART	QTY
A ALLEN KEY	1 Pc

PART	QTY
C M6 x 35mm	4 Pcs

PART	QTY
E BARREL NUT	4 Pcs

PART	QTY
B JCBC M6 x 16mm	4 Pcs

PART	QTY
D M3.5 x 20mm	8 Pcs

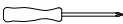
<i>Tools Required</i>	
	
SCREWDRIVER	

STEP 1

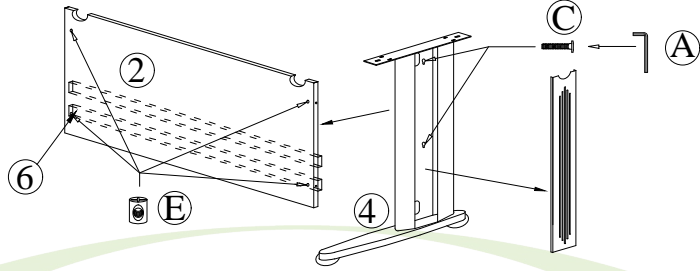

STEP 2

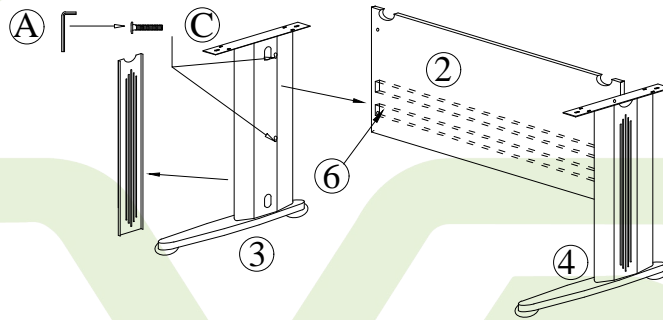

STEP 3

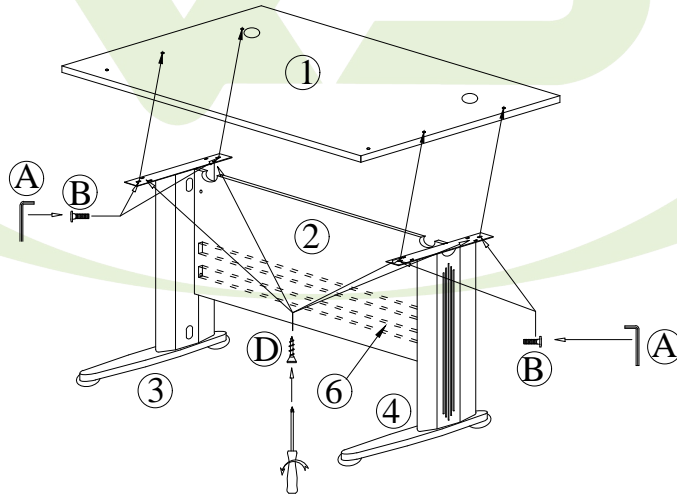

FINISHING

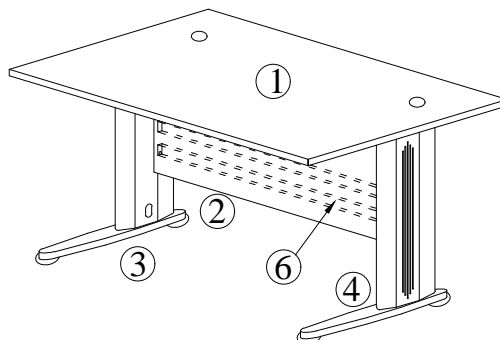

ASSEMBLY INSTRUCTION

MODEL : TT126

PART	QTY
A ALLEN KEY	1 Pc

PART	QTY
C M6 x 35mm	4 Pcs

PART	QTY
E BARREL NUT	4 Pcs

PART	QTY
B JCBC M6 x 16mm	4 Pcs

PART	QTY
D M3.5 x 20mm	8 Pcs

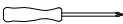
<i>Tools Required</i>	
	
SCREWDRIVER	

STEP 1

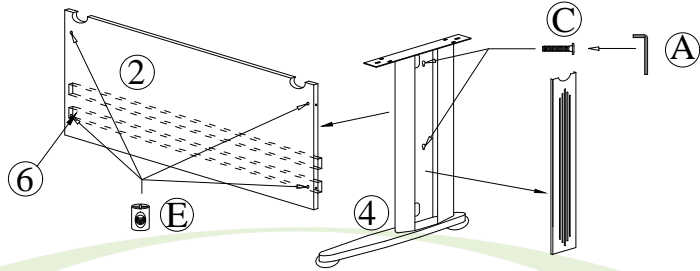

STEP 2

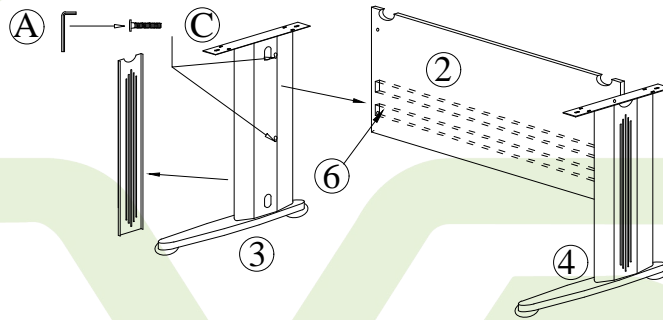

STEP 3

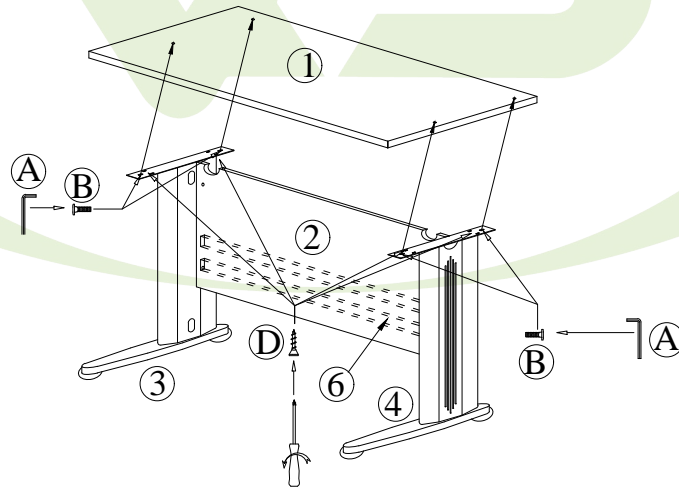

FINISHING

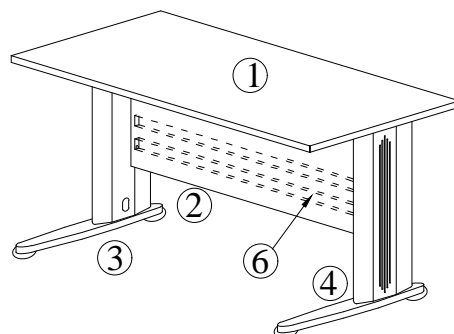

ASSEMBLY INSTRUCTION

MODEL : TOE24

PART	QTY
A ALLEN KEY	1 Pc

PART	QTY
C M6 x 35mm	4 Pcs

PART	QTY
E BARREL NUT	4 Pcs

PART	QTY
B JCBC M6 x 16mm	4 Pcs

PART	QTY
D M3.5 x 20mm	8 Pcs

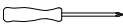
<i>Tools Required</i>	
	
SCREWDRIVER	

STEP 1

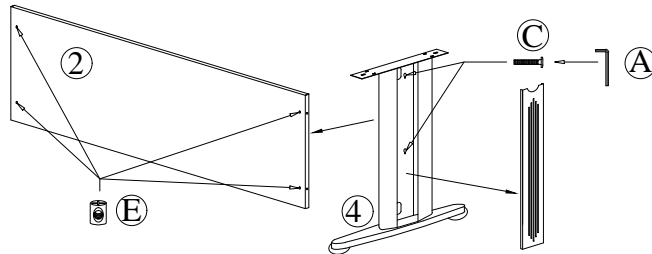

STEP 2

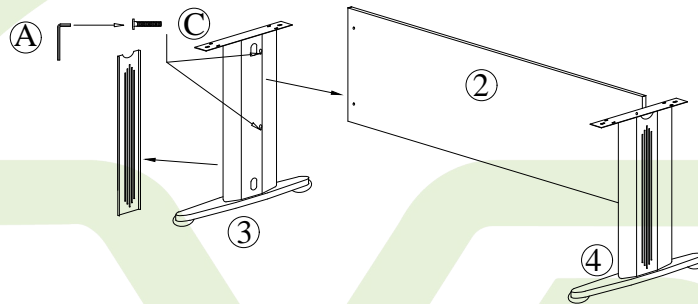

STEP 3

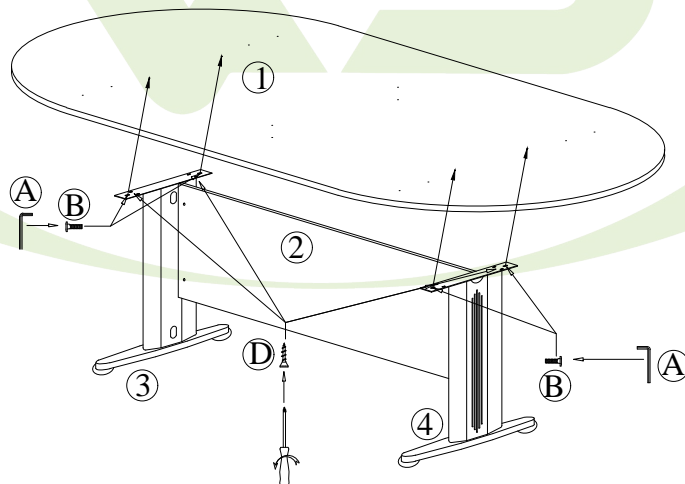

FINISHING

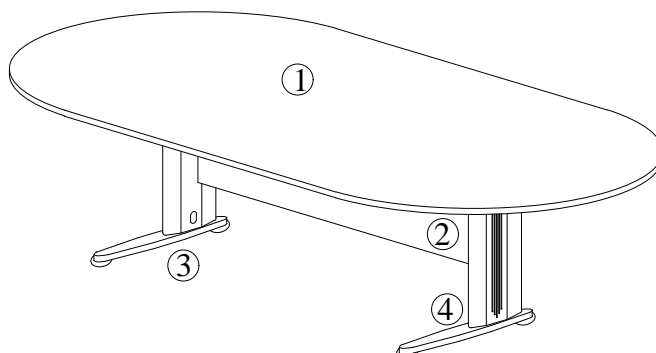

ASSEMBLY INSTRUCTION

MODEL : TOE18

PART	QTY
A ALLEN KEY	1 Pc

PART	QTY
C M6 x 35mm	4 Pcs

PART	QTY
E BARREL NUT	4 Pcs

PART	QTY
B JCBC M6 x 16mm	4 Pcs

PART	QTY
D M3.5 x 20mm	8 Pcs

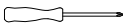
<i>Tools Required</i>	
	
SCREWDRIVER	

STEP 1

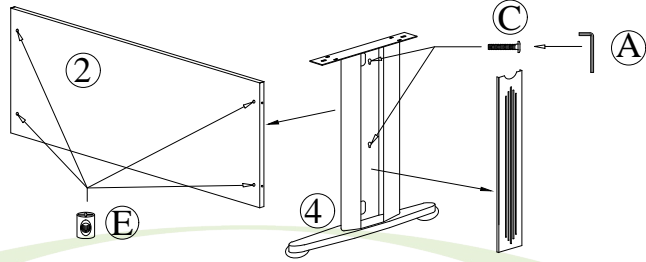

STEP 2

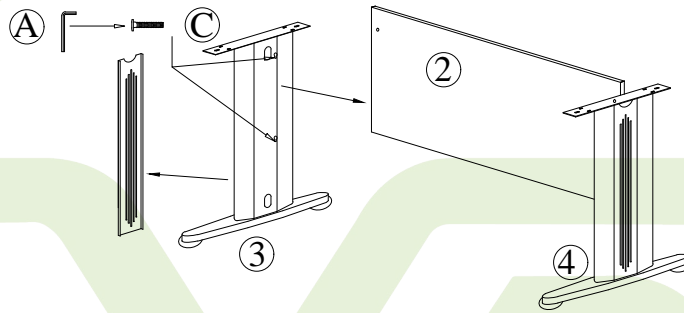

STEP 3

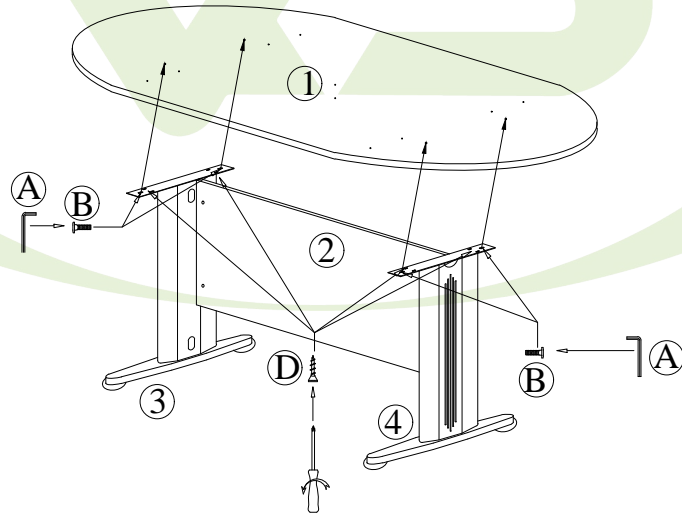

FINISHING

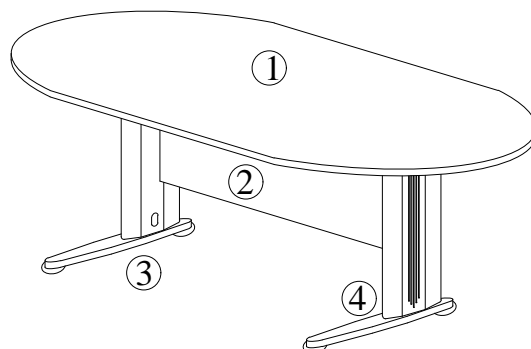

ASSEMBLY INSTRUCTION

MODEL : TMB180A

PART	QTY
A ALLEN KEY	1 Pc

PART	QTY
C M6 x 35mm	4 Pcs

PART	QTY
E BARREL NUT	4 Pcs

PART	QTY
B JCBC M6 x 16mm	4 Pcs

PART	QTY
D M3.5 x 20mm	8 Pcs

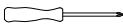
<i>Tools Required</i>	
	
SCREWDRIVER	

STEP 1

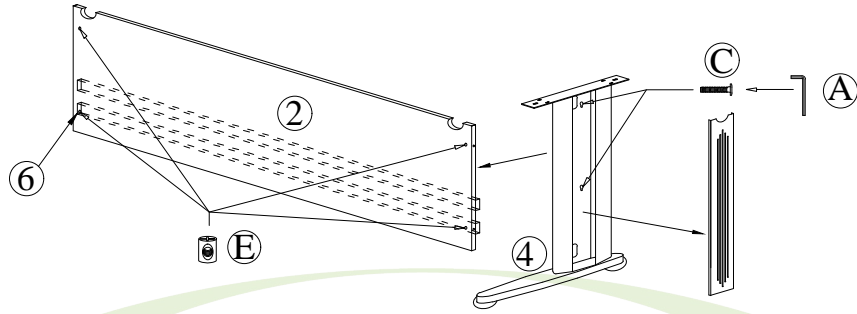

STEP 2

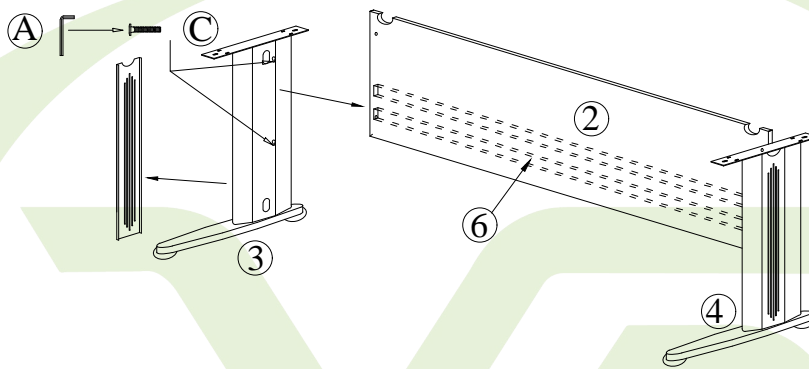

STEP 3

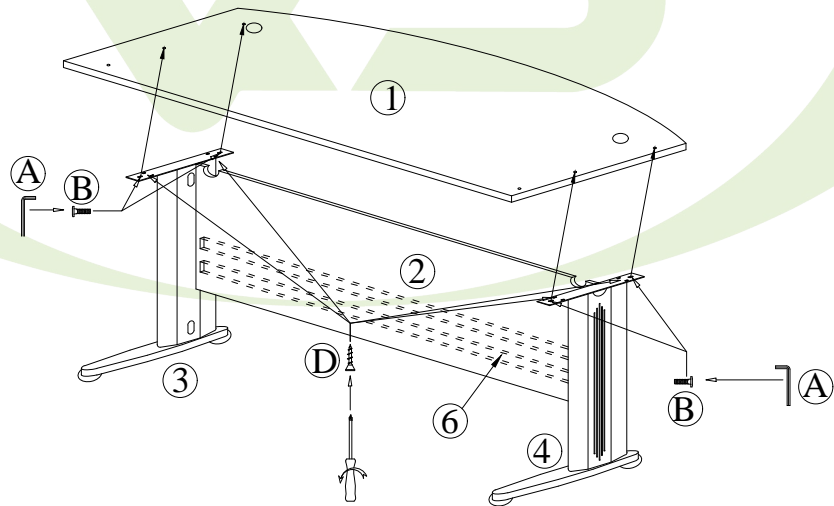

FINISHING

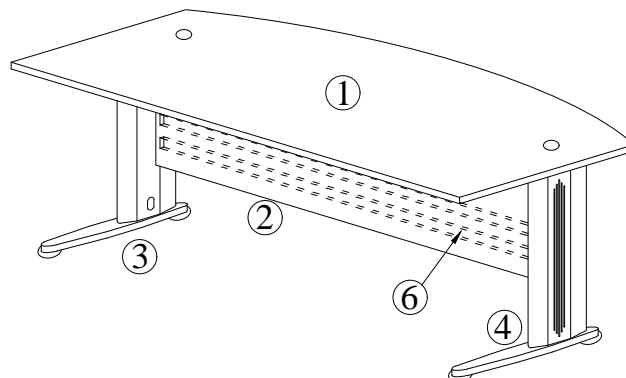

ASSEMBLY INSTRUCTION

MODEL : TMB55

PART	QTY
A ALLEN KEY	1 Pc

PART	QTY
C M6 x 35mm	4 Pcs

PART	QTY
E BARREL NUT	4 Pcs

PART	QTY
B JCBC M6 x 16mm	4 Pcs

PART	QTY
D M3.5 x 20mm	8 Pcs

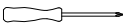
<i>Tools Required</i>	
	
SCREWDRIVER	

STEP 1

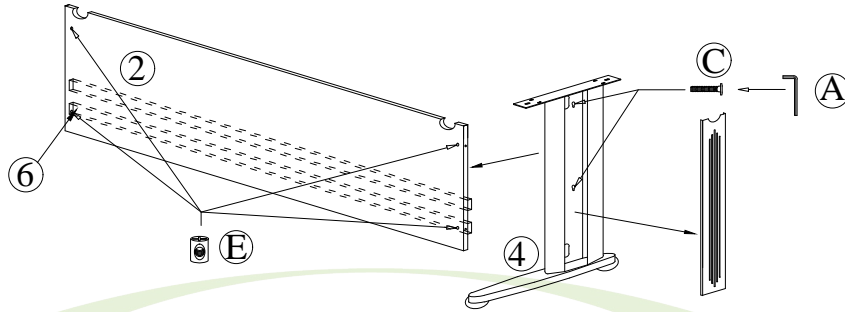

STEP 2 (A)

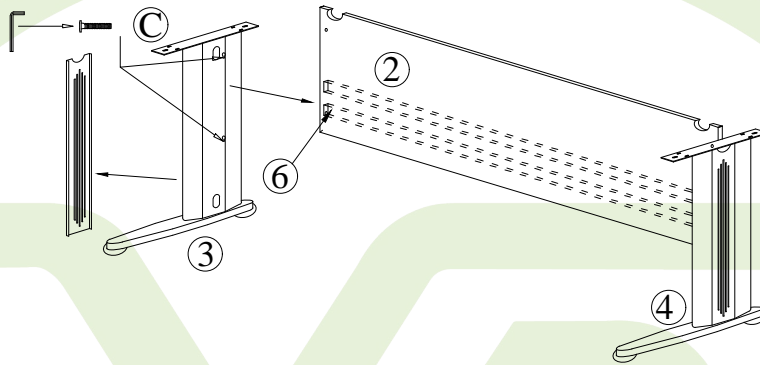

STEP 3

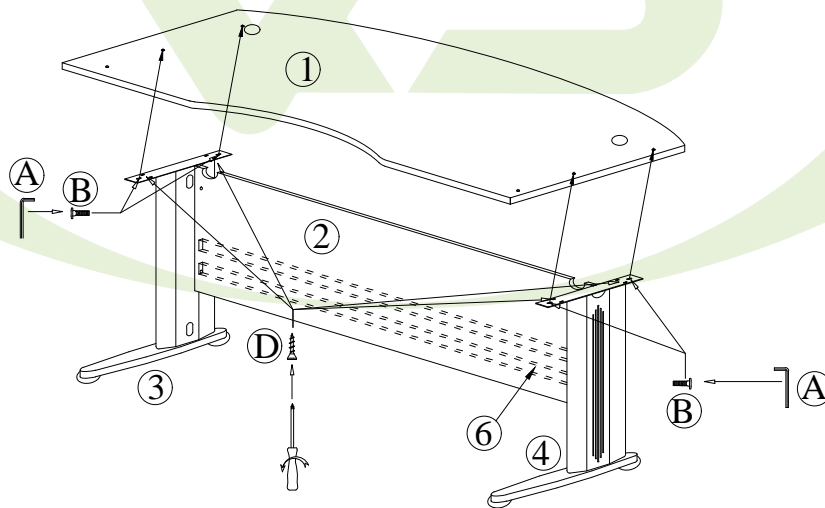

FINISHING

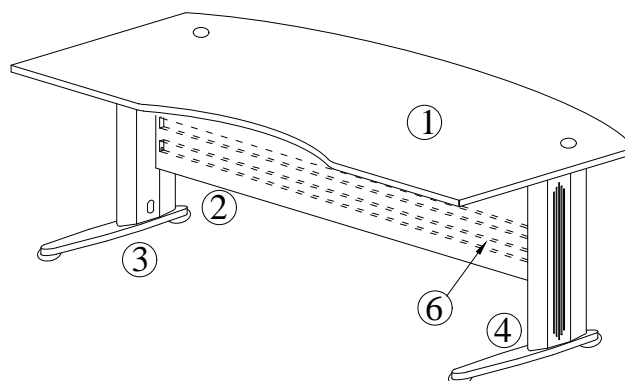

ASSEMBLY INSTRUCTION

MODEL : TMB33

PART	QTY
A ALLEN KEY	1 Pc

PART	QTY
C M6 x 35mm	4 Pcs

PART	QTY
E BARREL NUT	4 Pcs

PART	QTY
B JCBC M6 x 16mm	4 Pcs

PART	QTY
D M3.5 x 20mm	8 Pcs

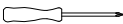
<i>Tools Required</i>	
	
SCREWDRIVER	

STEP 1

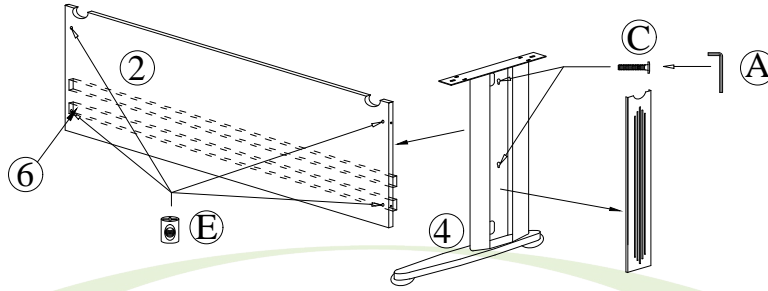

STEP 2

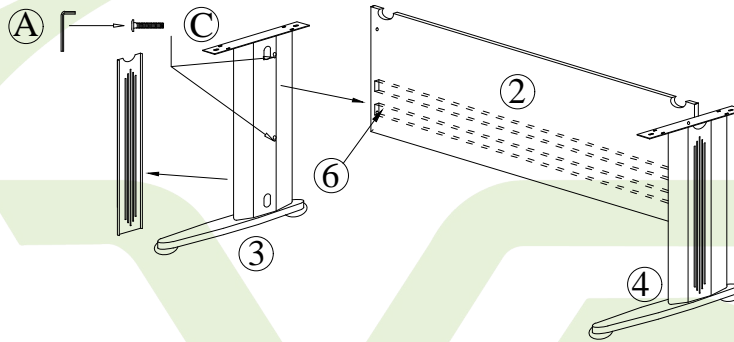

STEP 3

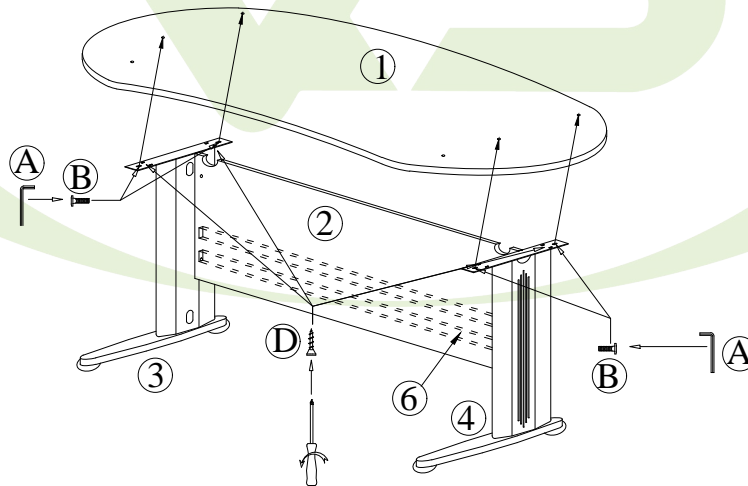

FINISHING

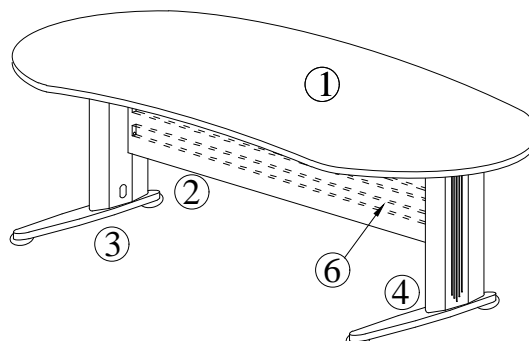

ASSEMBLY INSTRUCTION

MODEL : TMB11

PART	QTY
A ALLEN KEY	1 Pc

PART	QTY
C M6 x 35mm	4 Pcs

PART	QTY
E BARREL NUT	4 Pcs

PART	QTY
B JCBC M6 x 16mm	4 Pcs

PART	QTY
D M3.5 x 20mm	8 Pcs

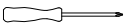
<i>Tools Required</i>	
	
SCREWDRIVER	

STEP 1

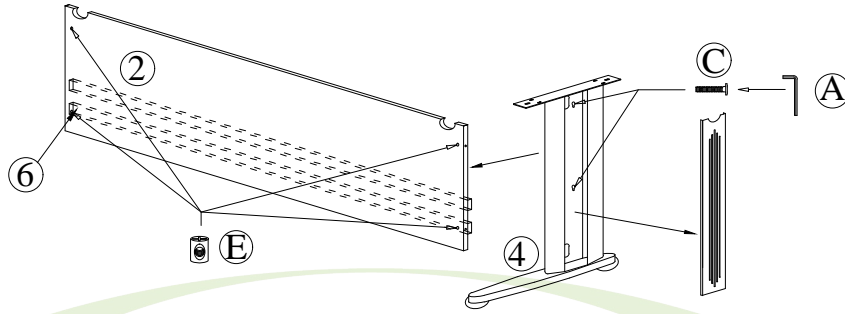

STEP 2 (A)

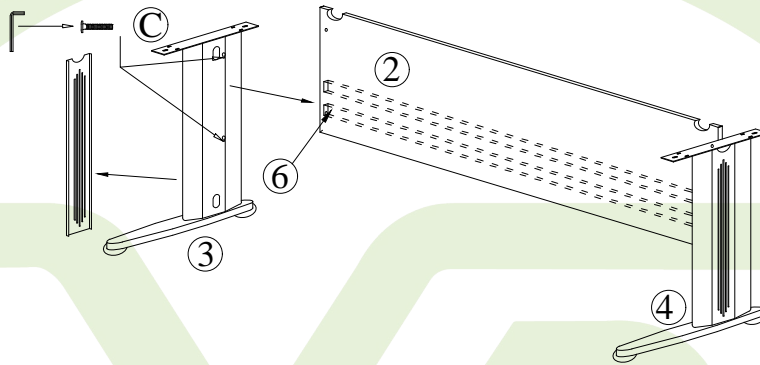

STEP 3

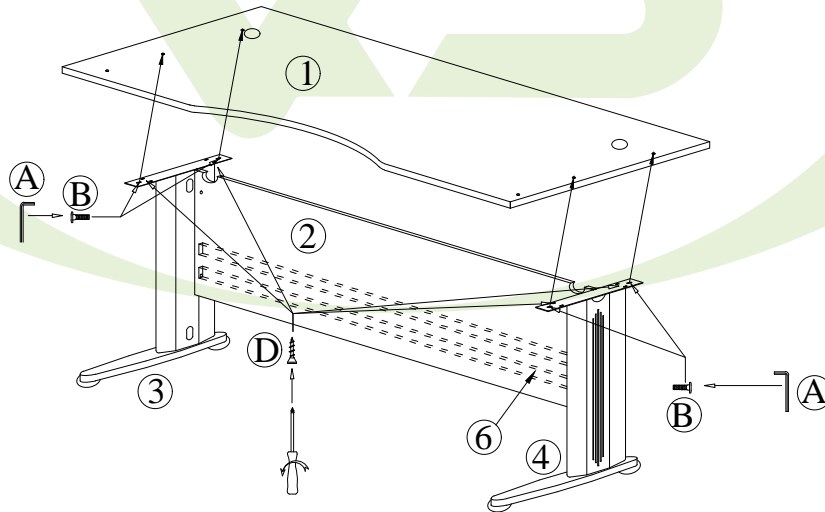

FINISHING

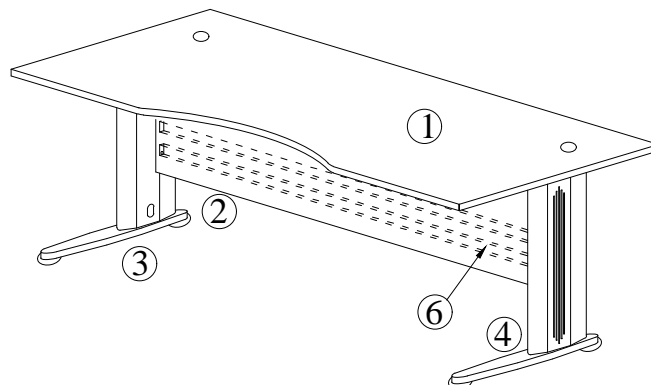

ASSEMBLY INSTRUCTION

MODEL : TL1815(L)

PART	QTY
A ALLEN KEY	1 Pc

PART	QTY
C M6 x 35mm	4 Pcs

PART	QTY
E BARREL NUT	4 Pcs

PART	QTY
B JCBC M6 x 16mm	6 Pcs

PART	QTY
D M3.5 x 20mm	12 Pcs

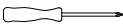
<i>Tools Required</i>	
	
SCREWDRIVER	

STEP 1

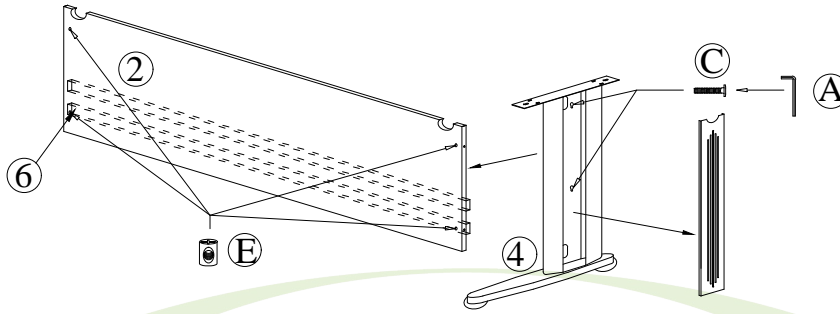

STEP 2

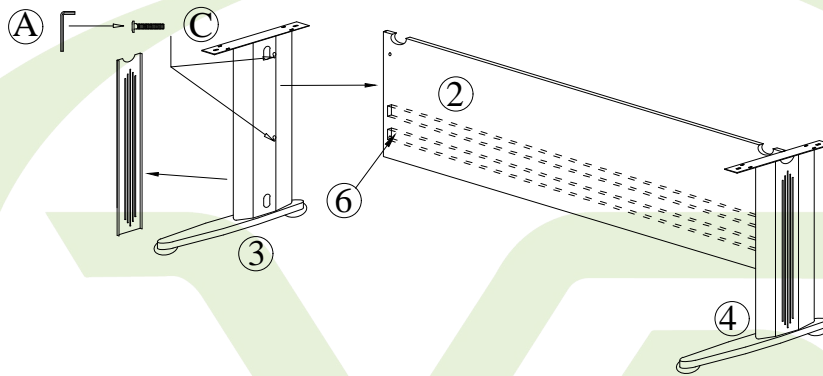

STEP 3

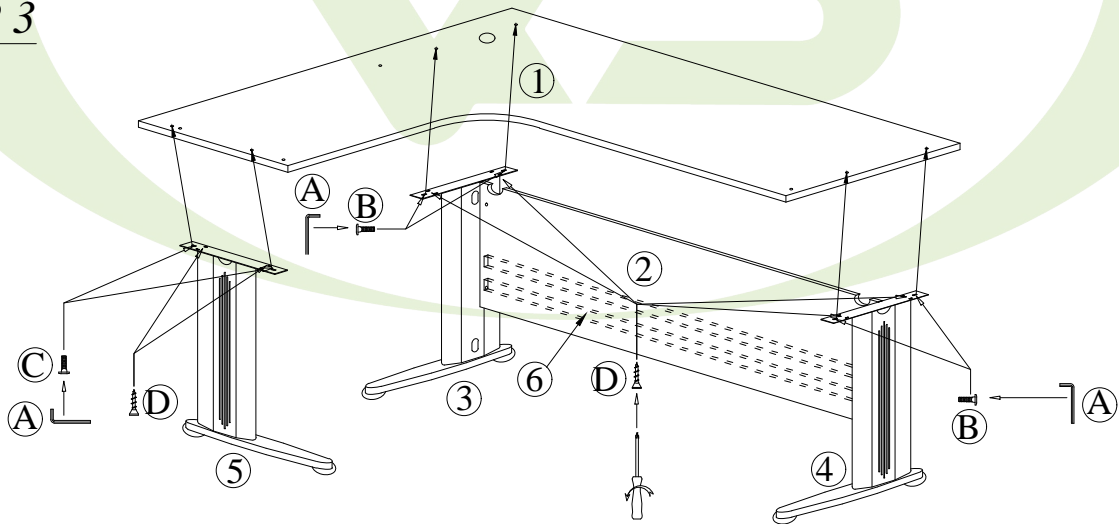

FINISHING

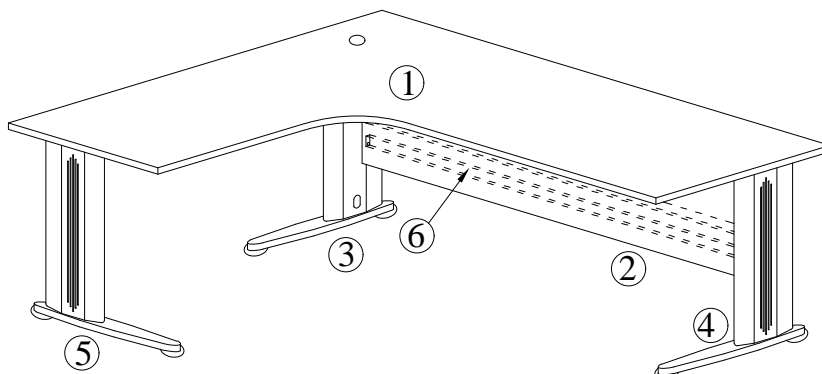

ASSEMBLY INSTRUCTION

MODEL : TL1515(L)

PART	QTY
A ALLEN KEY	1 Pc

PART	QTY
C M6 x 35mm	4 Pcs

PART	QTY
E BARREL NUT	4 Pcs

PART	QTY
B JCBC M6 x 16mm	6 Pcs

PART	QTY
D M3.5 x 20mm	12 Pcs

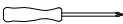
<i>Tools Required</i>	
	
SCREWDRIVER	

STEP 1

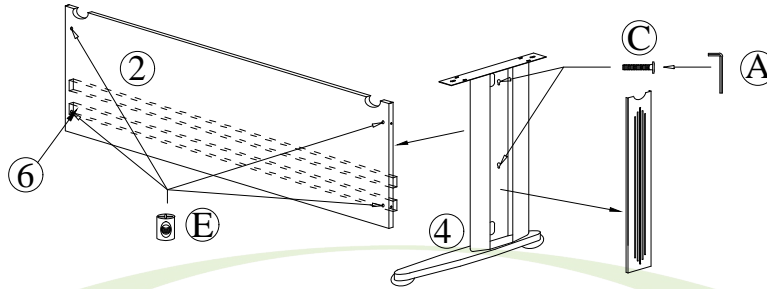

STEP 2

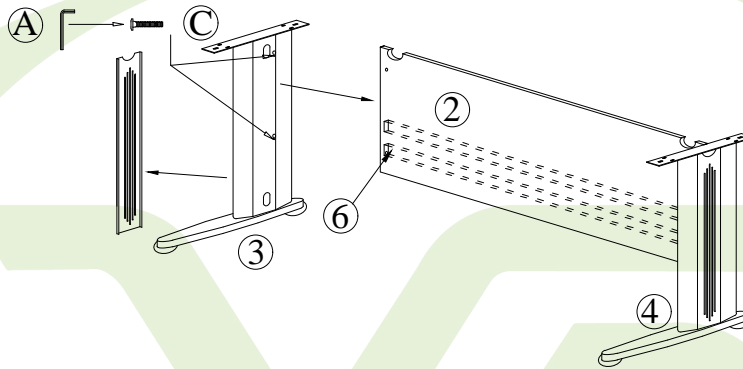

STEP 3

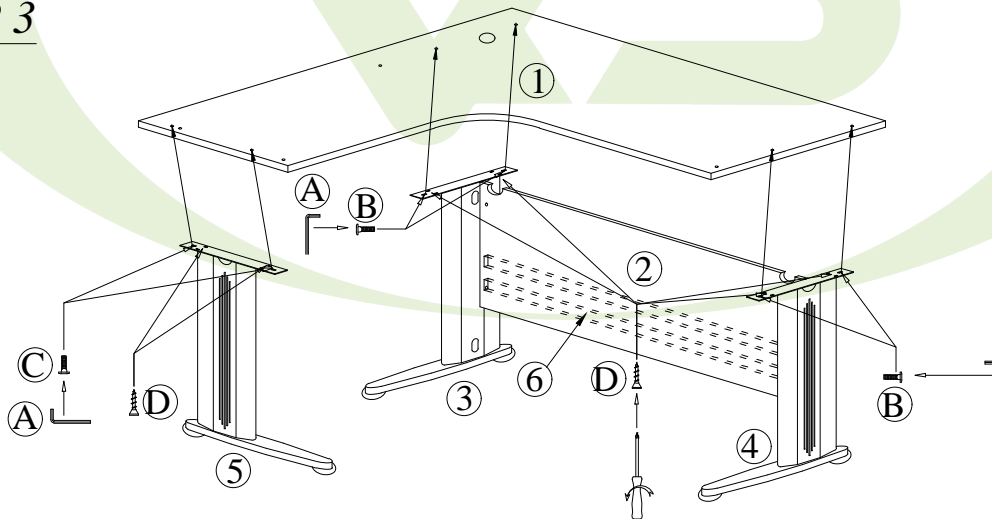

FINISHING

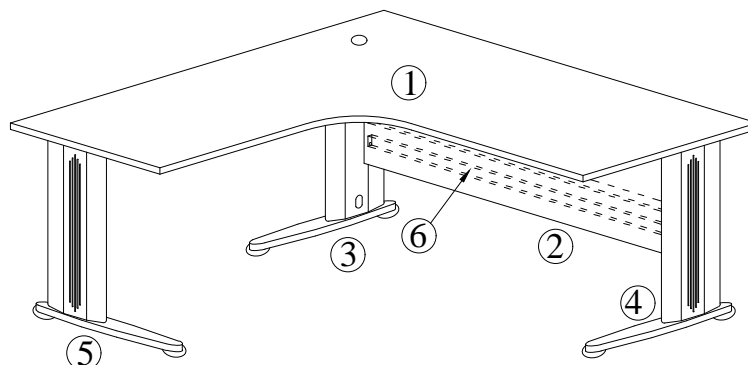

ASSEMBLY INSTRUCTION

MODEL : TIC36

PART	QTY
A ALLEN KEY	1 Pc

PART	QTY
C M6 x 35mm	8 Pcs

PART	QTY
E CSK M3.5 x 16mm D x 6	2 Sets

PART	QTY
G BARREL NUT	8 Pcs

PART	QTY
B JCBC M6 x 16mm	8 Pcs

PART	QTY
D M3.5 x 20mm	16 Pcs

PART	QTY
F YBV20	2 Sets

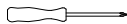
<i>Tools Required</i>	
	
SCREWDRIVER	

STEP 1

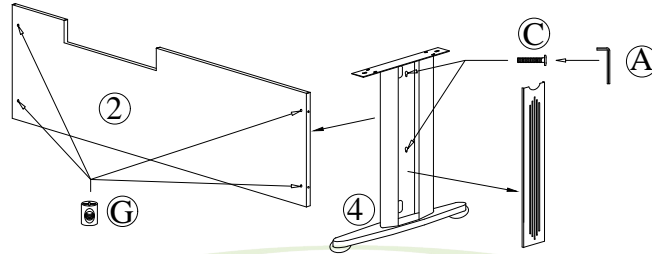

STEP 2

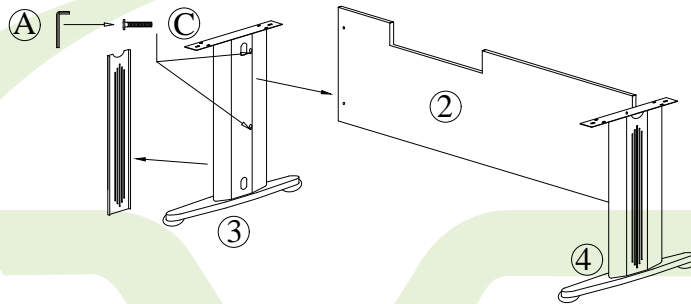

STEP 3

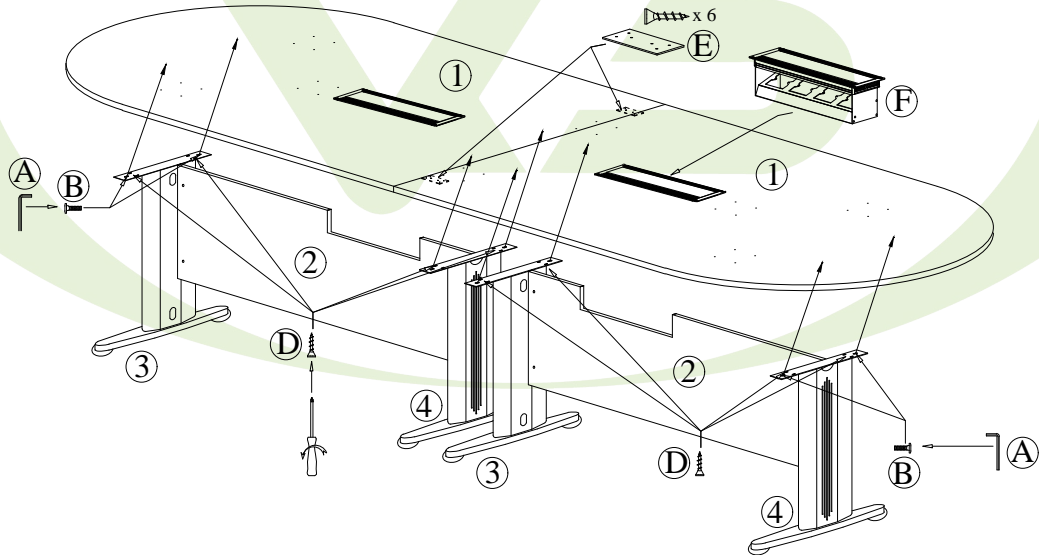

FINISHING

